

Basic parameters

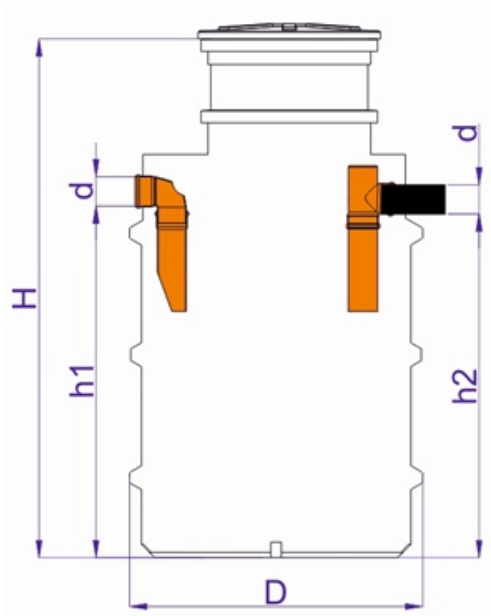
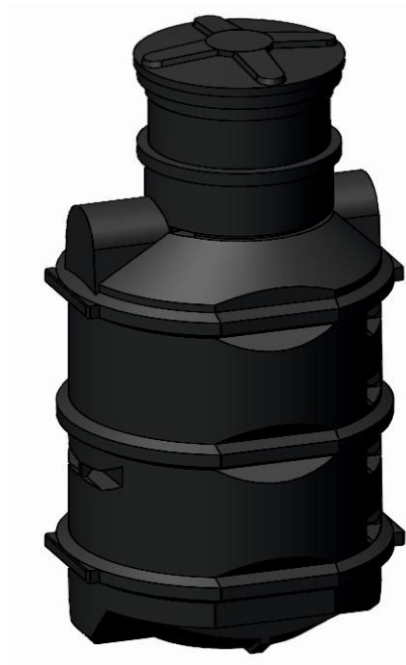

| Model | Nominal Flow | Length L/ Height H* | Width D | Height h1/h2 | Inlet/Outlet Diameter | Manhole Diameter | Total Capacity | Settler Capacity | Grease Capacity |
|--------|--------------|------------------------|---------|--------------|-----------------------|------------------|-------------------|-------------------|-----------------|
| | [l/s] | [m] | [m] | [cm] | [mm] | [mm] | [m ³] | [m ³] | [l] |
| STP-1 | 1 | 1,34* | 0,7 | 80/77 | 110 | 400 | 0,28 | 0,07 | 130 |
| STP-2 | 2 | 1,96* | 1,11 | 1,33/1,30 | 160 | 600 | 1,15 | 0,5 | 310 |
| STP-4 | 4 | 2,07* | 1,22 | 1,43/1,40 | 160 | 600 | 1,55 | 0,8 | 500 |
| STP-6 | 6 | 2,51* | 1,22 | 1,87/1,84 | 160 | 600 | 2,05 | 1 | 700 |
| STP-8 | 8 | 2,47* | 1,54 | 1,82/1,79 | 160 | 600 | 3 | 1,5 | 1200 |
| STP-10 | 10 | 2,8* | 1,54 | 2,15/2,12 | 160 | 600 | 3,6 | 1,7 | 1500 |

Individual solutions are also possible, guaranteeing larger volumes and larger flows.
At customer's request it is possible to change the diameter of the connections.

Optional devices:

- additional extensions
- alarm systems