

Hydrocarbon separators
with settler and coalescence insert
SKH, SKHD

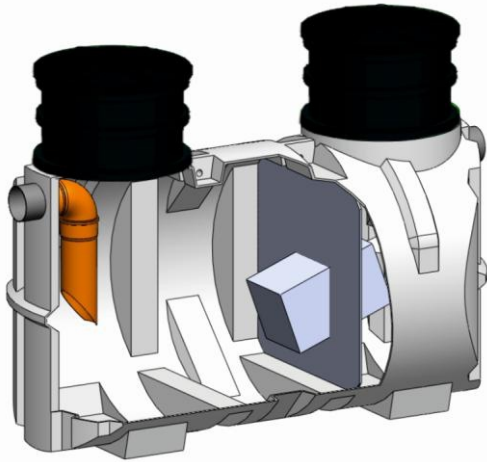

Basic parameters

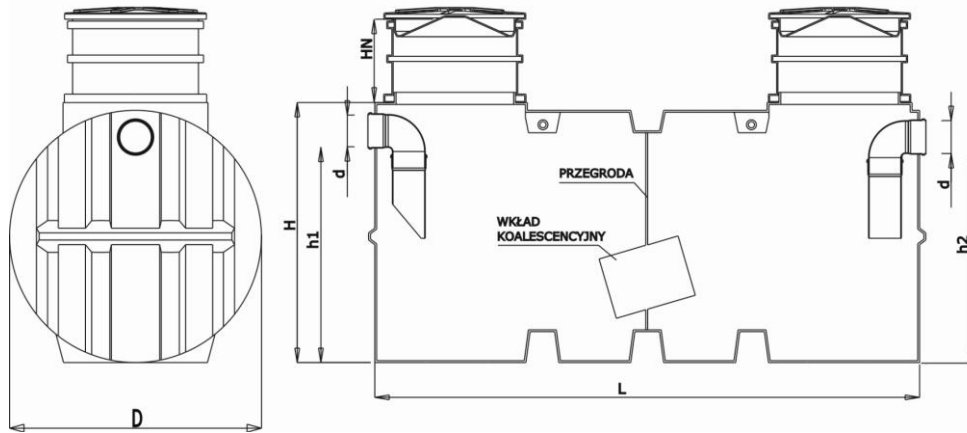

Model	Nominal Flow	Length L	Width D	Height h1/h2	Height H	Inlet/Outlet Diameter	Manhole Diameter	Total Capacity	Settler Capacity	Light Liquids Volume
	[l/s]	[m]	[m]	[cm]	[cm]	[mm]	[mm]	[m ³]	[m ³]	[l]
SKHD-2	2	1,73	1,2	104/100	125	110	600/600	1,7	0,7	250
SKH-3	3	1,73	1,2	99/95	125	160	600/600	1,7	0,6	290
SKHD-3	3	2,21	1,22	106/102	132	160	600/600	2,2	1,2	250
SKH-4	4	2,21	1,22	106/102	132	160	600/600	2,2	0,8	340
SKH-6	6	2	1,5	120/116	145	160	315/600	2,6	1,1	520
SKH-8	8	2,42	1,5	117/113	145	160	315/600	3,4	1,1	640

Height of extensions HN: 400 mm

Individual solutions are also possible, guaranteeing larger volumes and larger flows.

At customer's request it is possible to change the diameter of the connections.

Optional devices:

- additional extensions
- alarm systems